

# Kidde Advanced Delivery Fire Suppression System Component Description

## 3-Way Directional Valve

### FEATURES

- For use with Kidde Advanced Delivery Systems
- Cost-Effective Option for Protecting Multiple Hazards
- Pneumatic Operation Using Nitrogen Pilot Cylinder
- 3-Way Valve Comes Pre-Assembled with Pneumatic Actuator
- Nickel Plated Carbon Steel
- Low Loss Three Port Design
- UL Listed, File Number 4674

### DESCRIPTION

The Kidde Advanced Delivery Fire Suppression System offers the use of directional valves for protection of multiple hazards from one central storage bank of agent and nitrogen driver cylinders. When the same set of cylinders are used to protect different hazards, 3-Way Directional Valves may be included in the system. Since only one system (i.e., distribution piping and nozzles) can be entered and calculated at one time, it is necessary to create separate projects (.flc files) for each configuration. With respect to the directional valves, separate objects are used for a given valve size depending on the orientation of the valve. An “open” valve is used to allow agent to flow through the side (branch) outlet of the valve, and a “closed” valve would be used to allow agent to flow through the run outlet of the valve. When working with multiple files, the user should ensure that the type, diameter and length of any pipes common to more than one project file are identical. The pipe locking feature is useful here. In addition, the agent quantity per cylinder and area of the nitrogen restrictor orifice should be identical.

**Note:** Per NFPA 2001–In sections where a valve arrangement introduces sections of closed piping, such sections shall be equipped with pressure relief devices, or the valves shall be designed to prevent entrapment of liquid. For pressure relief of manifold arrangements using directional valves, use a safety outlet (P/N 844346).

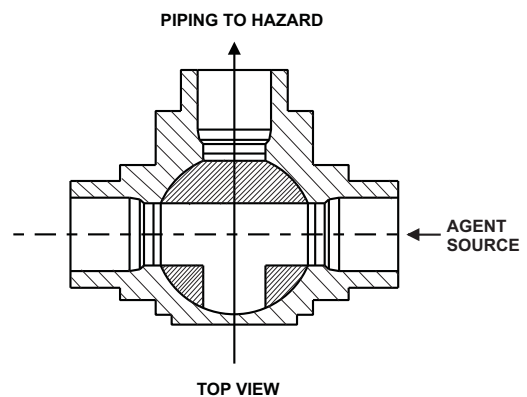
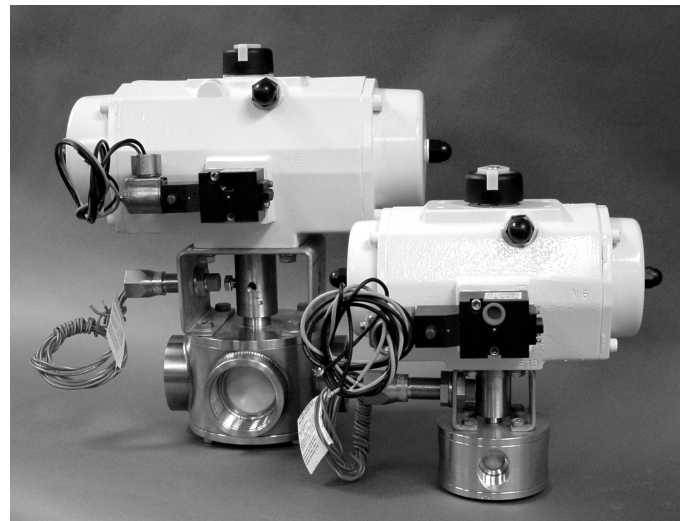

Figure 1. T Flow Position  
Valve Position Closed to Hazard

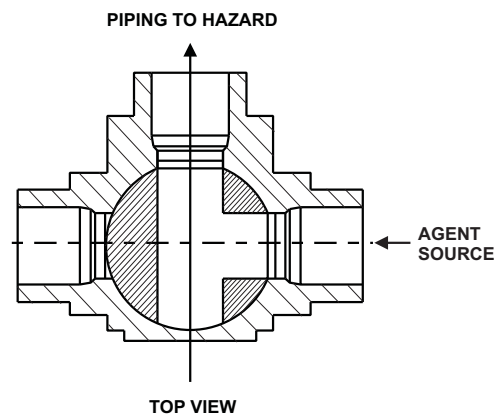

Figure 2. L Flow Position  
Valve Position Open to Hazard

## COMPATIBILITY

Series	For Use With
Kidde ECS Advanced Delivery with FM-200® Agent	X
Kidde ECS Advanced Delivery with 3M™ Novec™ 1230 Fire Protection Fluid	X

## OPERATION

A nitrogen pilot line is connected to each 3-Way Directional Valve. An electric control head is installed on each nitrogen pilot cylinder to actuate and release the nitrogen, which, in turn, pneumatically opens the valve. The nitrogen pilot line must be installed with a pressure regulator. The nitrogen line is then installed into the pneumatic solenoid that is attached to the pneumatic actuator. The pneumatic solenoid acts as a gate valve; when the signal is received from the panel to open the pneumatic solenoid, the pressure is then allowed to pass through the pneumatic actuator, which thereby turns the valve to the 90° “Open” orientation.

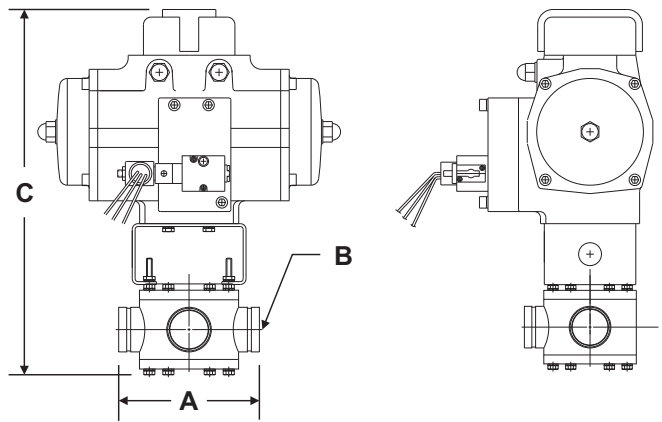

Figure 3. 3-Way Directional Valves  
(See Table 2 for more information.)



**WARNING**

The pneumatic actuator and pneumatic solenoid are rated for a pressure of 115 to 150 PSI (6.89 to 10.34 bar gauge). A pressure regulator must be installed in line to reduce the nitrogen pressure that is being released from the pilot cylinder. Pressure regulator P/N 06-118334-001 is factory set to 116 PSI (8 bar gauge).

Table 1. 3-Way Directional Valve

Ball Valve Size	Maximum Number from One Pilot Cylinder	Maximum Tubing 5/16" x 0.035" Weight	Maximum 1/4" Schedule 40 Pipe
4"	3	200 ft.	100 ft.
3"	5	200 ft.	100 ft.
2"	8	200 ft.	100 ft.
1 1/2"	8	200 ft.	100 ft.
1 1/4"	8	200 ft.	100 ft.
1"	8	200 ft.	100 ft.
3/4"	8	200 ft.	100 ft.
1/2"	8	200 ft.	100 ft.

Table 2. 3-Way Directional Valve Specifications

Part Number with Solenoid	Nominal Size	Dimensions			Valve Working Pressure	Breakaway Torque
		A*	B	C*		
90-220030-001	1/2"	3.50 in	0.688	11.23 in	400 PSIG	200 in lb
90-220030-002	3/4"	4.00 in.	0.824	12.13 in	400 PSIG	250 in-lb
90-220030-003	1"	4.00 in.	1.000	12.13 in	400 PSIG	250 in-lb
90-220031-001	1 1/4"	6.00 in.	1.380	13.69 in	400 PSIG	500 in-lb
90-220031-002	1 1/2"	6.00 in.	1.500	13.69 in	400 PSIG	500 in-lb
90-220031-003	2"	7.25 in.	2.000	15.66 in	400 PSIG	800 in-lb
90-220032-001	3"	11.00 in.	3.000	21.44 in	400 PSIG	3000 in-lb
90-220032-002	4"	13.38 in.	4.000	24.66 in	400 PSIG	4300 in lb

\*Note: Dimensions are approximate for the entire assembly.

Table 2. 3-Way Directional Valve Specifications (cont.)

Part Number with Solenoid	Nominal Size	Material	Inlets	Port	T-Flow Equivalent Length	L-Flow Equivalent Length
90-220030-001	1/2"	ENP Carbon Steel	NPT	Full	0.19 ft	1.83 ft
90-220030-002	3/4"	ENP Carbon Steel	NPT	Full	0.37 ft	3.61 ft
90-220030-003	1"	ENP Carbon Steel	NPT	Full	1.48 ft	9.31 ft
90-220031-001	1 1/4"	ENP Carbon Steel	NPT	Full	1.19 ft	11.65 ft
90-220031-002	1 1/2"	ENP Carbon Steel	NPT	Full	1.77 ft	12.08 ft
90-220031-003	2"	ENP Carbon Steel	NPT	Full	1.82 ft	13.75 ft
90-220032-001	3"	ENP Carbon Steel	Victaulic	Full	5.00 ft	26.01 ft
90-220032-002	4"	ENP Carbon Steel	Victaulic	Full	7.73 ft	32.42 ft

Table 2. 3-Way Directional Valve Specifications (cont.)

Part Number with Solenoid	Nominal Size	Actuator Mechanism	Actuator Type	Actuator Volume	Actuator Torque	Working Pressure	Maximum Pressure
90-220030-001	1/2"	Rack and Pinion	Spring Return	30 cu in	865 in-lb	115 PSIG	145 PSIG
90-220030-002	3/4"	Rack and Pinion	Spring Return	30 cu in	865 in-lb	115 PSIG	145 PSIG
90-220030-003	1"	Rack and Pinion	Spring Return	30 cu in	865 in-lb	115 PSIG	145 PSIG
90-220031-001	1 1/4"	Rack and Pinion	Spring Return	61 cu in	1877 in lb	115 PSIG	145 PSIG
90-220031-002	1 1/2"	Rack and Pinion	Spring Return	61 cu in	1877 in lb	115 PSIG	145 PSIG
90-220031-003	2"	Rack and Pinion	Spring Return	61 cu in	1877 in lb	115 PSIG	145 PSIG
90-220032-001	3"	Rack and Pinion	Spring Return	189 cu in	4887 in lb	115 PSIG	145 PSIG
90-220032-002	4"	Rack and Pinion	Spring Return	299 cu in	8288 in lb	115 PSIG	145 PSIG

## COMPONENTS

### 3-WAY DIRECTIONAL VALVES (P/NS 90-2200XX-00X)

The 3-Way Directional Valves are used for applications where a single bank of cylinders are used to protect multiple hazards (see the corresponding DIOM for additional information). The directional valves have a factory installed pneumatic, spring loaded actuator and range in sizes from 1/2 inch to 4 inches. The directional valves can be installed in the network, provided that they are accounted for in the software calculation. See Figure 3 and Table 2 for more information.

### Explosion Proof Pneumatic Solenoid (Optional) P/N 06-118384-001

The pneumatic solenoid is a cost-effective component that is used with the pneumatic actuators and 3-Way Directional Valves. With the solenoid, one nitrogen pilot cylinder can be used for multiple directional valves. The solenoid is factory set to normally closed. A signal from the panel opens the solenoid that is attached to the appropriate pneumatic actuator. Pressure is then allowed to pass through the solenoid and open the 3-Way Directional Valve (see the corresponding DIOM, for additional information). See Table 3 for valve operating data.

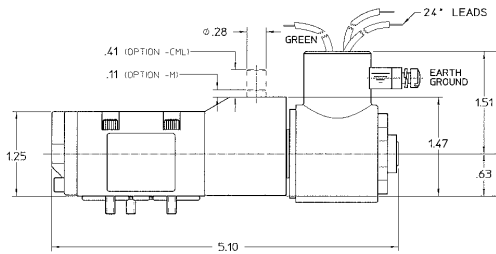

Figure 4. Pneumatic Solenoid

### Pressure Regulator (P/N 06-118334-001)

The pressure regulator is used up stream of the pneumatic solenoid to regulate the nitrogen pressure to 116 PSI (8 bar gauge) prior to operating the pneumatic actuator on the directional valve.

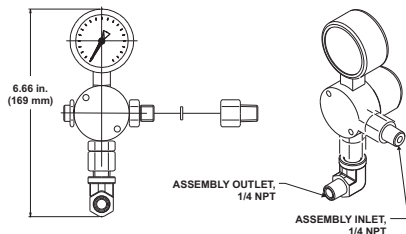

Figure 5. Pressure Regulator

## COMPONENT SPECIFICATIONS

Table 3. Pneumatic Solenoid Specifications

Description	Measurement
Pressure Range	15 to 115 PSIG
Voltage Rating	24 Vdc
Power Consumption (DC)	7W
Power Consumption (AC)	6W
Coil	CG5
Weight	0.80 lb
Ports	1/4" NPT
Includes:	Locking Manual Override Button

## ORDERING INFORMATION

Part Number	Description
<b>Valves with Solenoid</b>	
90-220030-001	3-Way Directional Valve, 1/2-inch
90-220030-002	3-Way Directional Valve, 3/4- inch
90-220030-003	3-Way Directional Valve, 1-inch
90-220031-001	3-Way Directional Valve, 1 1/4- inch
90-220031-002	3-Way Directional Valve, 1 1/2-inch
90-220031-003	3-Way Directional Valve, 2-inch
90-220032-001	3-Way Directional Valve, 3-inch
90-220032-002	3-Way Directional Valve, 4-inch
<b>Pressure Regulator</b>	
06-118334-001	Pressure Regulator, 116 PSI (8 bar)
38-509803-001	Pressure Regulator Kit
<b>Pneumatic Solenoid</b> <b>(Note: Part of Valve Assembly. Use below for spare parts only.)</b>	
06-118329-001	Pneumatic Solenoid, 24 Vdc
<b>Optional Solenoid</b>	
06-118384-001	Pneumatic Solenoid, Explosion Proof 24 Vdc

FM-200 is a registered trademark of E.I. du Pont de Nemours and Company. 3M and Novec are trademarks of 3M Company. Kidde is a registered trademark of Kidde-Fenwal Inc. All other trademarks are the property of their respective owners.

This literature is provided for informational purposes only. Kidde-Fenwal, Inc. assumes no responsibility for the product's suitability for a particular application. The product must be properly applied to work correctly. If you need more information on this product, or if you have a particular problem or question, contact Kidde-Fenwal, Inc.

